

# DC–DC CONVERTER IN MICROGRID FOR VOLTAGE REGULATION AND RIPPLE REDUCTION USING ELECTRIC SPRING TECHNOLOGY

P. Naga Lakshmi,\* R. Ashok Kumar,\*\* and K. Hari Krishna\*\*\*

## Abstract

For clean and renewable energy, microgrid is a vital process. Due to increasing penetration of renewable energy sources, requirement for DC microgrids is rising. Because of intermittent renewable energy sources, DC microgrids have to deal with unstabilized and fluctuating DC bus voltage. While designing and controlling of DC microgrids, main dominant problems to be considered are sudden changes in load, synchronization and interconnection of power converters, intermittent power generation of renewable energy sources. Electric springs are alternative to conventional energy storage systems for regulating and stabilizing load voltage and to mitigate ripples in voltage. In this paper, DC electric spring for DC microgrid to stabilize bus voltage and to protect critical loads using DC–DC bidirectional converter is proposed. DC electric spring connected in series with non-critical load will act like a smart load and protects critical load, which is connected in parallel with non-critical load, from voltage fluctuations and ripples. DC microgrid and electric spring are modelled using MATLAB/SIMULINK, and results are presented to check efficacy of proposed technique.

## Key Words

Electric Spring, renewable energy source, storage device, DC Microgrid, bidirectional converter, critical load, voltage stabilization.

## 1. Introduction

Traditional energy sources are replaced by renewable energy sources due to increasing environmental pollution and

energy crisis. DC microgrid is becoming more widespread and companionable because of its constancy, effectiveness and expediency [1]. Major drawbacks in AC microgrids like reactive power, synchronization of phase angle and frequency of voltage are not taking place in DC microgrids. As the requirement for smarter and efficient power grids is increasing DC power system is adopted by certain emerging grid applications [2]. Smarter control of grid is required for small-scale power systems like remote communication stations, hybrid transportation vehicles, commercial buildings, data centres, spacecrafts, low voltage ceiling grid applications, and data centres. Traditional load such as induction motor behaves like a DC load if operated as an inverter controlled variable speed drive [3]. As renewable energy sources like photovoltaic systems, fuel cells and storage devices like batteries are inherently DC in nature, the total microgrid can be integrated in the form of DC without any requirement of DC–AC power conversion, which improves system efficiency and reduces switching transients. DC microgrid with distributed generation and power management is explained in [4]. With efficient demand and source management, distributed generation increases reliability, reduces transmission line losses, eliminates distribution losses and curtails maintenance cost and customer price. Remote electrification, continuous power during grid disturbances and scalability enhancement are possible with these configurations in DC microgrid. Bus voltage oscillations, fluctuations in bus voltage because of irregular renewable energy sources, power inequity amid loads and sources are the main problems to be dealt with while designing or operating DC microgrids [5]. A voting-based smart energy management system for a grid connected solar-wind-biomass-based hybrid energy system using rule-based decision making is proposed in [6]. DC microgrid is useful compared to AC microgrid because of its compatibility with renewable energy sources like solar PV and with storage devices such as battery and fuel cells and with DC loads [7]. For DC microgrid with irregular energy sources and variable loads for firm and dependable operation, storage devices are essential [8]. Storage system of DC microgrid behave as a safeguard to stock excess

\* Department of Electrical and Electronics Engineering, Bapatla Women's Engineering College, Bapatla, AP, India; e-mail: nagalakshmi.ponnuri84@gmail.com

\*\* Department of Electrical Engineering, Faculty of Engineering and Technology, Annamalai University, Annamalai Nagar, Chidambaram, Tamil Nadu, India; e-mail: ashokraj\_7098@rediffmail.com

\*\*\* Department of EEE, Kallam Haranadhareddy Institute of Technology, Chowdavaram, Guntur District, AP, India; e-mail: harikrishnaketha81@gmail.com

Corresponding author: P. Naga Lakshmi

Recommended by Dr. Partha Sarathi Subudhi  
(DOI: 10.2316/J.2022.203-0423)

energy and supply it back to the system when it required. A grid connected hybrid energy system with solar, wind and gas as energy sources and battery as storage device is proposed in [9]. DC bus voltage and load voltage are main important parameters to be considered while designing DC microgrid. Voltage at DC bus and at load replicates the constancy of DC networks and is the key variable to be controlled for efficient operation. Control strategies for regulation of load voltage in DC networks are mostly measured from the interpretation of adaptable terminal busses [10]. Coordinated droop control method is proposed in [11] for voltage regulation, but steady-state error is the main drawback of this droop control. Traditional power sharing controllers used in AC power systems are not appropriate to DC microgrids as these are not coupled through utility frequency. A centralized controller which balances power requirement of demand and power availability from sources in DC microgrid is proposed in [12]. A droop control for voltage which controls local voltage of each source using droop coefficients is proposed in [13]. To optimize droop coefficients, a gain scheduling technique is proposed in [14]. For hybrid AC–DC microgrids, a coordinated droop control technique is proposed in [15]. Presence of constant power loads, which may have negative impedance, will increase oscillations in DC bus and destabilizes the DC microgrid [16]. These oscillations can be reduced using filters [17], additional energy storage devices [18] or by load shedding [19]. An IIoT enabled energy management system for a grid connected solar wind hybrid system to provide consistent power to the load and to store a fixed amount of energy in the battery of electric vehicle is proposed in [20]. Electric spring is initially proposed for AC power system to stabilize bus voltage. Three kinds of electric springs are proposed till now, in which two types are connected in series with non-critical load and third kind of electric spring was connected with DC–AC power converters. In addition, with voltage stabilization electric spring can reduce frequency fluctuations, can reduce storage energy requirements and can improve power quality in AC power grids [21]. In [22], for stabilizing DC microgrid, predictive control synthesis based on fuzzy control is proposed. The mentioned method is not strong in contradiction of the transients of the DC microgrid and the limitations of energy storage system. In [23], to reduce current ripples, a current-source inverter is placed as electric spring. Using a low pass filter, line current ripples are measured and taken as feedback to neutralize them using PI controller. But if load currents are dynamic which depends on connected load, voltage source converter are advantageous compared to current source converter. In [24], impacts of non-critical loads variation on the ES voltage-regulation effect were analysed, but effect of faults on electric spring is not considered. A process of unbalanced voltage suppression caused by constant power loads in a bipolar DC distribution system is proposed in [25]. However, sudden changes in atmospheric conditions are not considered as DC distribution system reliably depends on renewable energy sources. In [26], electric spring to improve power quality of solar photovoltaic system fed DC microgrid is proposed. However, mentioned technique is advisable for

low power applications and regulation of voltage will be affected if applied for high power applications. In this paper, a conceptual framework involving DC electric spring for the application in DC microgrid to stabilize bus voltage is proposed. The technology of DC electric spring is applied directly at load side to protect critical load from voltage fluctuations. Electric spring is connected in series with non-critical load to act like a smart load to maintain ripple free and stabilize voltage to critical loads. DC electric spring proposed in this paper for microgrid with renewable energy sources can handle voltage fluctuations caused by sudden atmospheric changes. The main contributions of the paper are as follows:

- Designing of DC microgrid with wind and PV as renewable energy sources, battery and fuel cell as storage devices and critical and non-critical loads at utility side.
- Extraction of maximum power from wind generation and solar generation using maximum power point tracking algorithms.
- Controlling of DC–DC converters using MPPT of renewable energy sources and controlling of DC–DC bidirectional converter of storage devices.
- Realization of electric spring technology using bidirectional converter to feed critical loads through DC bus.
- Controlling of electric spring using proposed approach to achieve stabilized and regulated voltage at critical load.

This paper is organized as follows. Section 2 explained about electric spring technology, section 3 explained about DC microgrid and its renewable energy sources and section 4 presented simulation results using MATLAB/SIMULINK.

## 2. Electric Spring

Electric spring is a device which has been designed using passive electronic components and works as similar to mechanical spring. As mechanical spring stores mechanical energy, electric spring can store electric energy and can provide voltage support whenever required. Another advantage of electric spring is its damping nature of electric oscillations. According to Hooke's law, mechanical spring can be represented as [27]

$$F = -kx \quad (1)$$

**Potential energy stored in the spring can be represented as**

$$PE = \frac{1}{2}kx^2 \quad (2)$$

**where**  $x$  is the displacement vector,  $k$  is the spring constant and  $F$  is the force vector. Capacitance can be used as storage device in an electric spring. Similar to mechanical spring, electric spring can be described on the basis of current injection and described as [28]

$$q = \begin{cases} Ce_a & \text{inductive mode} \\ -Ce_a & \text{capacitive mode} \end{cases} \quad (3)$$

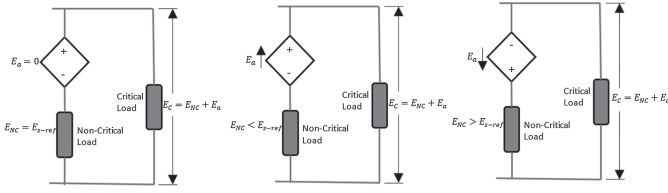

Figure 1. Principle of electric spring.

$$q = \int i_c dt \quad (4)$$

where  $C$  is the capacitance of the capacitor used to store electric energy,  $e_a$  is the capacitor's potential difference and  $i_c$  is the current flowing through the capacitor. As per (3), electric charge storage behaviour of capacitor can support the voltage requirement of system connected. Electric charge stored in capacitor is directly proportional to integral of the current flowing through it as shown in (4). Hence, current controlled voltage source can be used to represent electric spring in an equivalent circuit.

As shown in Fig. 1, critical load is connected in parallel with series connection of non-critical load and electric spring. Electric spring provides the voltage support required by critical load and damp any oscillations produced across it.  $E_C$  is the critical load voltage which is the sum of non-critical load voltage  $E_{NC}$  and voltage support from electric spring  $E_a$ . Voltage support by the electric spring  $E_a$  can be produced by controlling voltage across capacitor using current flowing  $i_c$  across it. Hence, the voltage across electric spring can be generated in both directions using current flow as per requirement of critical load. With capacitor as storage device and by connecting electric spring in series with non-critical load, power variation due to renewable power generation can be handled by reactive power adaptation. By replacing capacitor with a better storage device like battery, both active and reactive powers can be handled and controlled. Another improvement for electric spring is by removing series non-critical load, it can modify as bidirectional grid connected power converter for better controlling of active and reactive power and for improved voltage regulation. Maximum work done till now by researchers concentrated on AC power systems. Three mentioned configurations of electric springs can be used in AC power systems depending on requirement. Application of DC-DC converter-based bidirectional electric spring on DC power systems is studied in this paper. As reactive power is not there in DC systems, electric spring with battery storage device with a series non-critical load is considered here. Electric spring may damp the oscillations by dissipating them in non-critical load and another advantage of NC load is that the electric spring can be bypassed during faults occurred in the converter. The electric spring in series with NC load can regulate the power level of storage device attached to it and can control the power dissipated in NC load. Therefore, required energy to balance demand and supply of power system can be highly condensed. The basic schematic diagram of a DC electric spring is shown in Fig. 2. A bidirectional DC-DC converter is adopted as electric spring with battery as energy

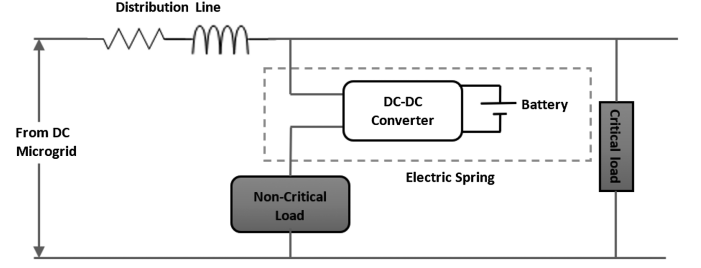

Figure 2. Electric spring with non-critical load connected across DC grid and load.

storage device. A non-critical load is connected in series with DC-DC converter. The injected voltage from the bidirectional DC-DC converter into the line is regulated by considering the fluctuation in DC microgrid voltage. This voltage can be controlled by adaptive adjustment of dissipation of power in NC load and energy storage systems by means of delivering or absorbing process. These two factors will make critical load voltage to be controlled and stabilized by making demand side power to follow fluctuations of grid voltage. Main disturbances to be considered while regulating DC voltage in DC microgrid using electric spring are uneven voltage, droop effect, switching transients and sudden device failure. The reasons for uneven voltages in DC microgrid are due to intermittency of renewable energy sources and variation in power demand. Droop effect on voltage is due to the presence of impedance in distribution line. While point in the distribution line moves further to power source, voltage drop increases and hence there is a drop in voltage regulation. During heavy load conditions, drop in voltage regulation further worsens due to increase in line current. In case of AC lines, due to the presence of capacitors on distribution lines, droop effect can be reduced. Droop effect has to be considered while controlling the power converter of electric spring to get better voltage regulation. Switching transients are due to the presence of power inverters for AC loads in line. Switching transients with the frequency of switching of inverters will inject current ripples and oscillations in voltage. Due to these transients, critical load voltage may exceed limits and effect critical and sensitive loads.

### 3. DC Microgrid

Figure 3 shows the DC microgrid with wind, PV and FC as renewable energy sources and battery as energy storage device to supply DC or AC loads. Depending on climatic conditions, available energy from these energy sources is constrained and indeterminate. And their energy features are nonlinear. Battery banks and fuel cell as energy storage devices will improve reliability of the grid and improve demanding requirement of consumers. Remaining energy after demand requirement converted by wind turbine and PV system is stored in energy storage devices and using electrolyser, hydrogen can be produced, stored and used if any requirement is there. Storing hydrogen for future use will improve reliability and efficient utilization of renewable energy.

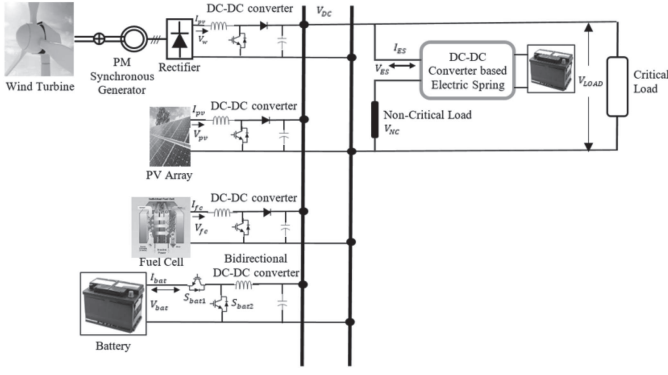

Figure 3. Wind-PV-FC-battery-based DC microgrid with electric spring.

### 3.1 PMSG with DC-DC Converter

Wind power available from a wind turbine having a cross-sectional area of  $A$  is given as [29]

$$P_{wind} = \frac{1}{2} \rho A V_w^3 \quad (5)$$

where  $\rho$  is the air density in  $kg/m^3$  and  $V_w$  is the wind speed in m/s. Power coefficient  $C_p$  defines the amount of power available after wind turbine for conversion is given as

$$P_w = C_p P_{wind} \quad (6)$$

Maximum value of  $C_p$  is Betz limit 0.593.  $P_w$  is the power extracted from rotor of the wind turbine given as

$$P_{wind} = \frac{1}{2} \rho A V_w^3 C_p(\beta, \gamma) \quad (7)$$

$\lambda$  is tip speed ratio given as

$$\lambda = \frac{w_r R}{V_w} \quad (8)$$

where  $R$  is the radius of rotor in m,  $w_r$  is the rotor speed in rad/s and  $\beta$  is the pitch angle. PMSG is chosen to convert mechanical energy available from wind turbine into electrical energy due to its advantages like no excitation losses, no rotor current and can be used without gear box. Output electrical energy of PMSG is interfaced to DC microgrid using a rectifier for rectification and a DC-DC converter for regulated and boosted DC voltage. Power transfer from PMSG to DC microgrid depends on DC link voltage. Representative structure of PMSG with diode bridge rectifier interfaced to DC microgrid through DC-DC boost converter is shown in Fig. 4. Controlling process of IGBT switch in DC-DC converter is shown in Fig. 5. Flow chart for MPPT algorithm of PMSG DCDC converter is shown in Fig. 6. MPPT will determine the reference inductor current  $I_{wref}$  to be extracted from rectifier for a particular DC microgrid voltage  $V_{dc}$  to get maximum power from wind generation system. PI controller in control system of DC-DC converter will govern duty cycle of switching pulses to be given to IGBT switch to maintain  $I_{wref}$  current through inductor.  $I_{wref}$  is the current determined by

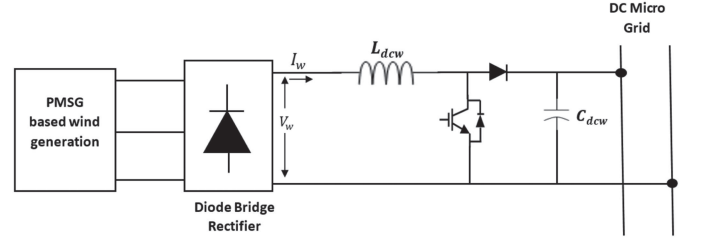

Figure 4. DC-DC converter for PMSG-based wind generation system.

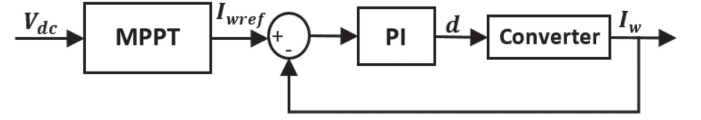

Figure 5. Control system for DC-DC converter of wind generation system.

MPPT algorithm for a particular  $V_{dc}$ . Maximum power extraction from wind turbine can be possible at  $(dP_w)/(dW_r) = 0$ , and as back emf is directly proportional to rotor speed hence

$$\frac{dP_w}{dV_{dc}} \quad (9)$$

For a particular wind speed, using MPPT algorithm variation in DC link voltage will determine the change to be maintained in  $I_w$  to extract maximum power from PMSG.

### 3.2 PV with MPPT-based DC-DC Converter

PV panels can be interfaced with DC microgrid through DC-DC boost converter which will operate at maximum power point using INC (incremental conductance) based MPPT algorithm. By operating the DC-DC converter at MPPT voltage, solar energy from PV arrays can be utilized abundantly and extraction of maximum power is possible. Incremental conductance algorithm determines the operating point at which maximum power point can be extracted. PV system with DC-DC converter connected with microgrid is shown in Fig. 7.

Control diagram of DC-DC converter-based PV system is shown in Fig. 8.  $V_{mpp}$  is the voltage at which maximum power can be extracted from PV panels. This voltage can be determined by incremental conductance algorithm by taking array voltage and current as inputs as shown in Fig. 9. Power  $P_{pv}$  from PV array is given as

$$P_{pv} = V_{pv} I_{pv} \quad (10)$$

Variation of power with respect to voltage is

$$\frac{dP_{pv}}{dV_{pv}} = \frac{d(V_{pv} I_{pv})}{dV_{pv}} \quad (11)$$

$$\frac{dP_{pv}}{dV_{pv}} = I_{pv} + V_{pv} \frac{dI_{pv}}{dV_{pv}} \quad (12)$$

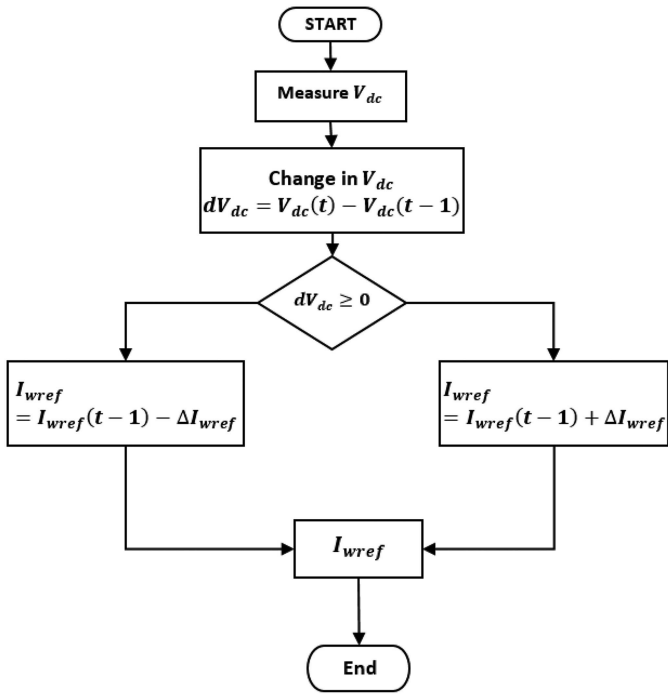

Figure 6. Flow chart for MPPT algorithm of PMSG DC-DC converter.

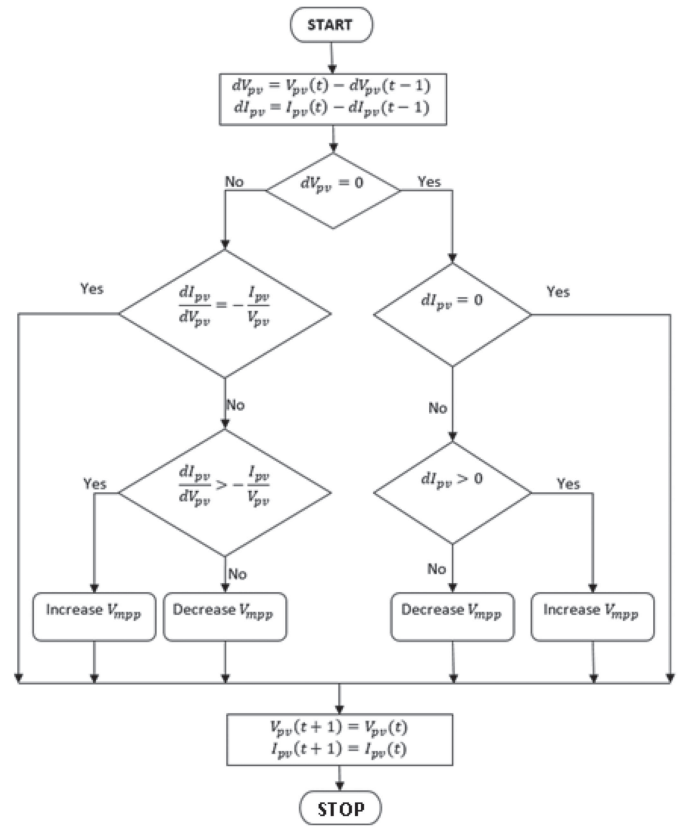

Figure 9. Flow chart for incremental conductance MPPT algorithm.

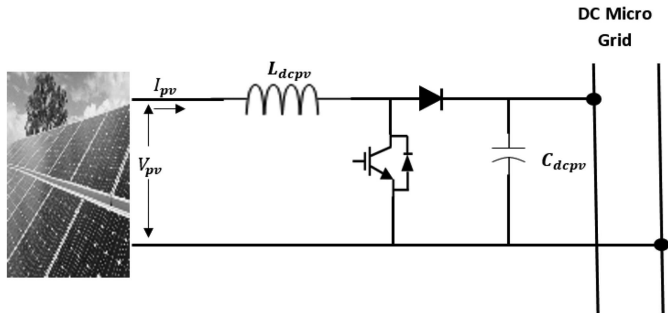

Figure 7. DC-DC converter-based PV system.

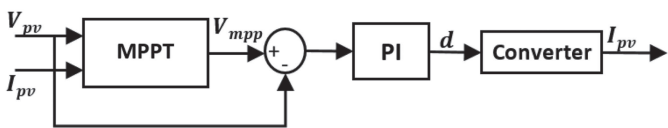

Figure 8. Control system for DC-DC converter of PV generation.

from characteristics of PV array, at maximum power point, slope is equal to zero.

$$0 = I_{pv} + V_{pv} \frac{dI_{pv}}{dV_{pv}} \quad (13)$$

Hence at maximum power point

$$\frac{dI_{pv}}{dV_{pv}} = - \left( \frac{I_{pv}}{V_{pv}} \right) \quad (14)$$

#### 4. Battery with Bidirectional Converter

Balancing of power in DC microgrids will use DC bus voltage as pointer. Regulation of DC bus voltage by considering power balance is possible by droop control method. The droop characteristics of voltage and current be considered for automatic power management of battery while regulating DC voltage.

$$V_{dc} = (V_{dc}^* \pm \Delta V) - D_c I_{batout} \quad (15)$$

$I_{batout}$  is the output current of battery bidirectional converter,  $D_c$  is the droop coefficient,  $\Delta V$  is the maximum variation of voltage and  $V_{dc}^*$  is the reference DC bus voltage. With this droop control methodology, DC bus voltage will be oscillated if there is any variation in output power of the renewable energy sources in microgrid or load power. Because of this condition, the stability and quality of microgrid get effected. This type of flaws will be rectified by adapting virtual inertia-based droop control. The inertia factor plays a significant role in configuring DC bus voltage. During transient states, DC bus voltage is stabilized by adding additional power with the aid of droop coefficient and virtual inertia. For virtual inertia-based droop control, the classic droop control is modified as [30]

$$V_{dc} = (V_{dc}^* \pm \Delta V) - D_c I_{batout} + D_c Z_{vi} \frac{d(V_{dc}^* - V_{dc})}{dt} \quad (16)$$

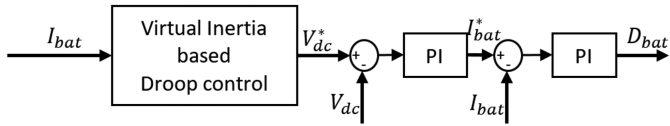

Figure 10. Control system for bidirectional converter of battery.

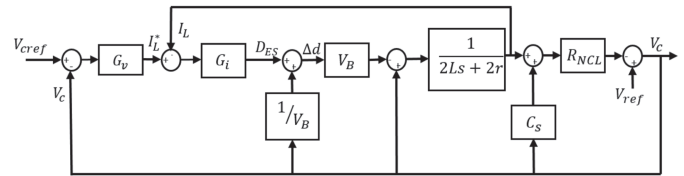

Figure 12. Control block diagram of electric spring.

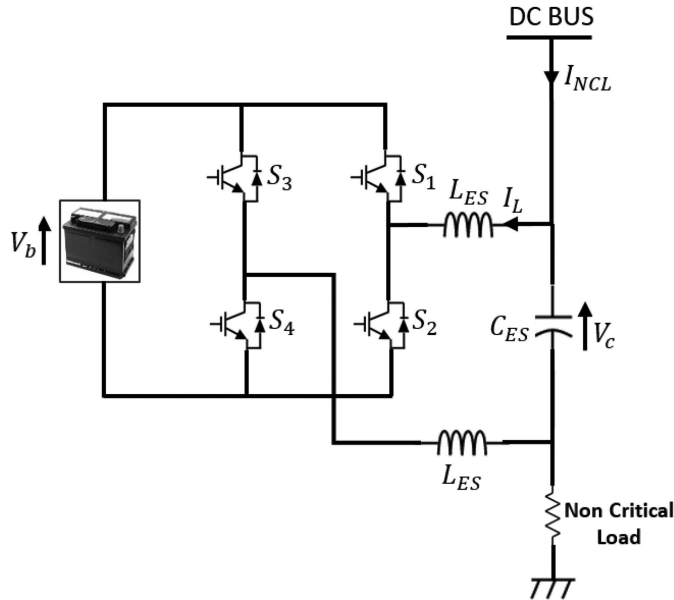

Figure 11. Schematic diagram of electric spring.

Control process for virtual inertia-based droop control system for bidirectional converter of battery is shown in Fig. 10.

## 5. Bidirectional DC–DC converter

Bidirectional DC–DC converter for the proposed DC electric spring in series with non-critical load connected to a DC bus is shown in Fig. 11.  $L_{ES}$  and  $C_{ES}$  are filter inductance and capacitance electric spring, and  $V_B$  is the battery voltage. State space model of the system is given as [31]

$$\begin{bmatrix} \dot{v}_c \\ \dot{i}_L \end{bmatrix} = \begin{bmatrix} -\frac{1}{R_{NCL}C} & -\frac{1}{C} \\ \frac{1}{2L} & -\frac{r}{L} \end{bmatrix} \begin{bmatrix} v_c \\ i_L \end{bmatrix} + \begin{bmatrix} \frac{V_{ref}}{R_{NCL}C} \\ -\frac{\Delta d V_B}{2L} \end{bmatrix}. \quad (17)$$

Block diagram of control circuit of cascaded voltage and control loop is shown in Fig. 12. Transfer function of outer voltage controller is represented as  $G_V$  and inner current controller is represented as  $G_I$ . Both controllers are PI controllers and gains are calculated using trial and error method.  $V_{ref}$  is the voltage difference between reference DC bus voltage or critical load voltage and non-critical load voltage.

## 6. Simulation Results

A simulation model based on MATLAB /SIMULINK has been developed for the proposed DC electric spring and its

control structure to analyse its performance. System power rating is 8 Kw, PV array rating is 150 V, 12 A and 2 Kw and battery rating is 150 V and 500 Ah.  $L_{dcpv}$  and  $C_{dcpv}$  are 1 mH and 100  $\mu$ F.  $L_{dcbat}$  and  $C_{dcbat}$  are 5 mH and 100  $\mu$ F.  $L_{dcfc}$  and  $C_{dcfc}$  are 5 mH and 100  $\mu$ F.  $L_{dcwind}$  and  $C_{dcwind}$  are 10 mH and 100  $\mu$ F. PMSG rating is 3 Kw. Two types of loads are considered as critical and non-critical and electric spring with battery backup is connected in series with non-critical load in order to deliver the voltage and power requirements of critical load. Two different case studies/investigations are implemented/executed to observe/realize efficacy of electric spring and its control structure to maintain regulated voltage and power across critical load. As renewable energy is considered as the main source of/for microgrid, weather conditions will affect the generated power and DC bus voltage. Change in irradiation, change in wind speed are the two possibilities considered here.

### 6.1 Change in Irradiation/Varying Irradiance

The efficiency of solar cell depends on quality of irradiation and temperature of the day. Because of the varying irradiation, DC bus voltage may change as duty cycle derived from MPPT depends on maximum power from PV for that particular voltage. Hence, critical load voltage will be affected. By providing voltage support from the electric spring, variation in critical load voltage can be reduced. For the experimental analysis, initially the solar irradiance has been fixed at its base values of 1000 w/m<sup>2</sup>. Then at a time gap of one second, it has been decreased to 400 w/m<sup>2</sup>. Afterwards, again it is increased to 600, 800 and 1000 w/m<sup>2</sup> in 2, 3 and 4 s, respectively. Variation of irradiance, PV output power due to this variation and PV voltage and current are graphically represented in Fig. 13.

Similarly, a typical wind speed of 12 m/s has been chosen for the case studies. There is a good response for this test case. The output power of the PMSG, voltage and current due to the constant wind speed of 12 m/s are clearly illustrated in Fig. 14. A simple review has been done with another renewable energy source. Here, a fuel cell has been subjected to simulated analysis. The output power, voltage and current of fuel cell are depicted in Fig. 15. A sample load of 6KW is connected to a DC bus with a view of assessing the proposed method (to reveal the performance of the proposed method). The outcomes of this process are exhibited in Fig. 16. The output characteristics of the battery are portrayed in Fig. 17. An attempt has been made by injecting the voltage for the case of varying impedance by the electric spring. The results are appreciable. The outcomes are recorded. Voltage of



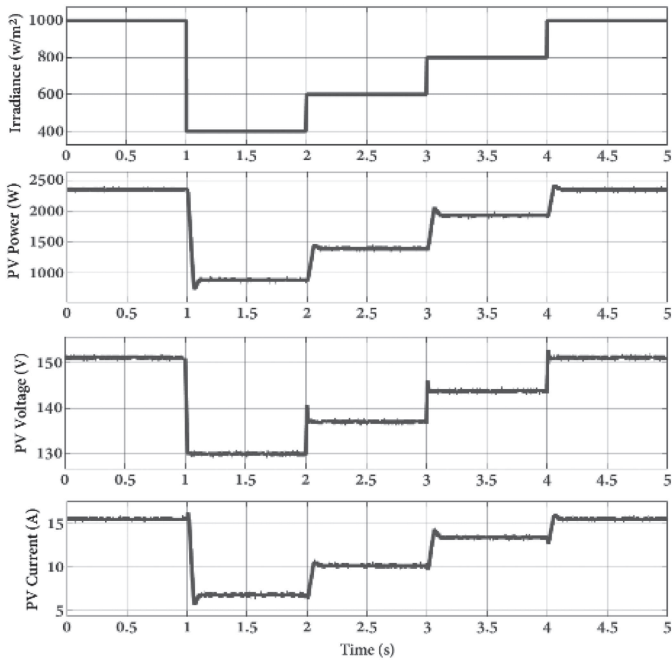

Figure 13. Irradiance, PV power, PV voltage and PV current during variation of Irradiance.

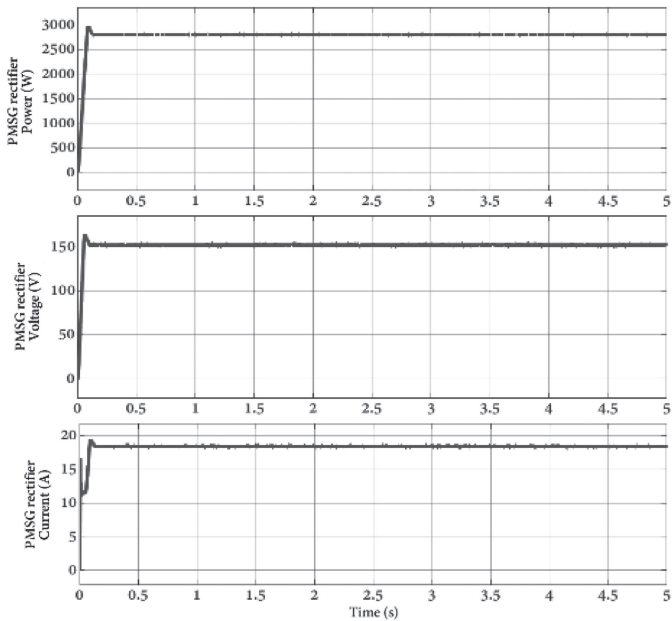

Figure 14. PMSG rectifier output power, voltage and current for 12 m/s wind speed.

DC bus, load and injected voltage by the electric spring are graphically displayed in Fig. 18. It is understood that the PV output power and its voltages are varying with respect to the variation in irradiance. When an irradiance is reduced to  $400 \text{ w/m}^2$ , immediately the output power from the PV is declined to  $900 \text{ w/m}^2$  and the voltage is also coming down to 130 V. The performance of the system gets improved wherever the rate of change of irradiance is increased. The operational profile of DC bus is greatly depending on the PV cells output. The smaller drop in PV

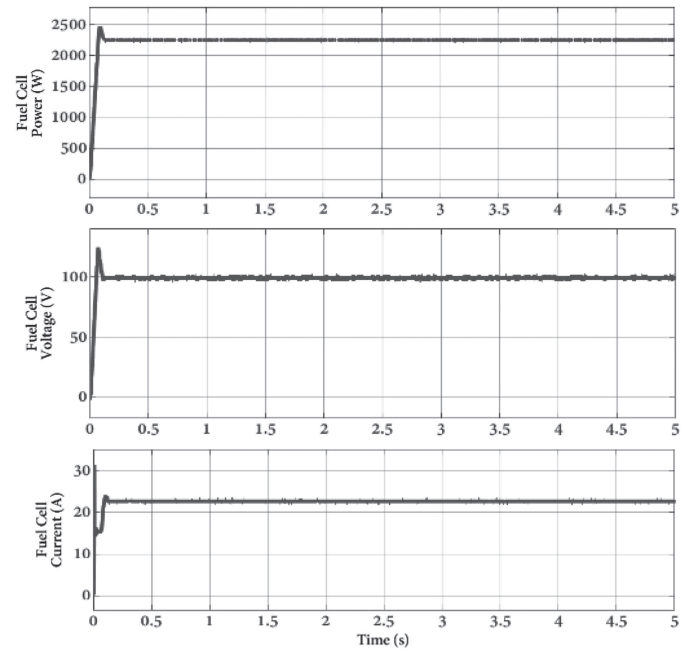

Figure 15. Fuel cell output power, voltage and current.

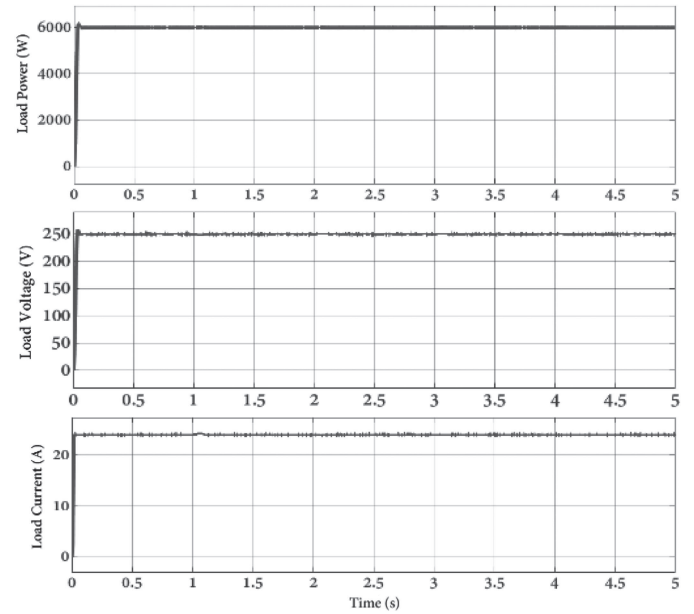

Figure 16. Load power, voltage and current for 6 KW load.

output voltage will seriously affect the functionality of DC bus. A test case reveals that the reduction of PV output by 20 V will reduce the DC bus voltage to 8 V. It is noted that the maximum fluctuation in DC bus is around 20V when there is a variation in irradiation. Practically, this voltage will be supplied to critical load in the absence of proposed electric spring which may affect the workability of critical load. In this situation, the electric spring will inject the additional voltage for the critical load. This process will ensure the constant voltage to the critical load and also minimizes the ripples. The waveform of critical load voltage and the injected voltage by the electric spring are precisely visualized in Fig. 18. It is realized/noticed that

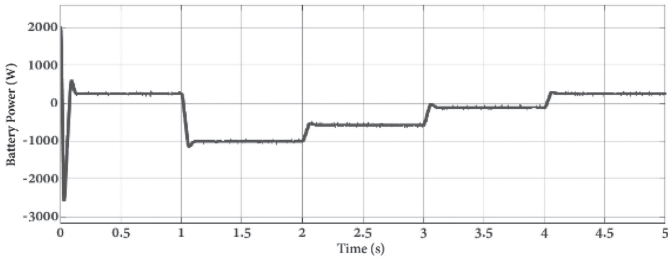

Figure 17. Battery power.

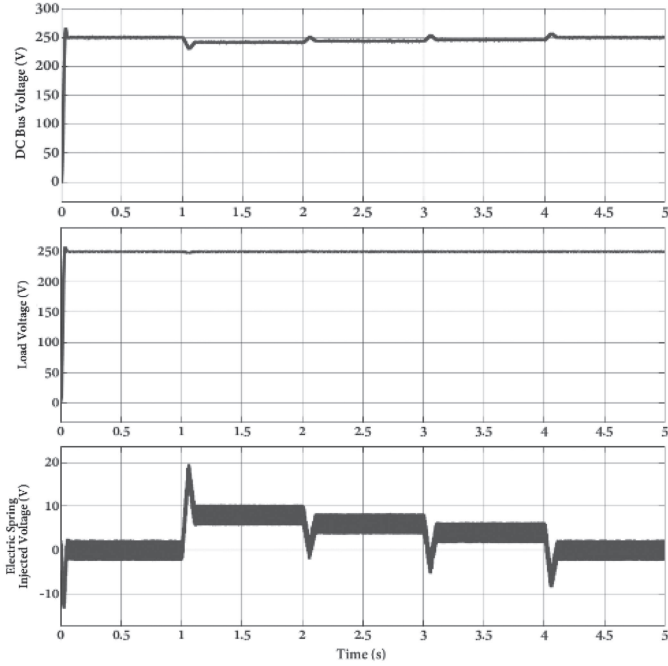

Figure 18. DC bus voltage, Load voltage and electric spring injected voltage during variation of Irradiance.

the ripples in DC bus voltage are in the range of 2V, and these ripples are reduced in steady state by the injection of voltages from the proposed electric spring. Finally, the ripples in load voltages are minimized to the range of 0.4 V. Transient behaviour of voltages when irradiance is changed is shown in Figs. 19 and 20.

## 6.2 Change in Wind Speed

It is worthy to mention that the changes in wind speed may influence the capacity expansion of plants. It also affects the performance of other energy/power supply systems. An analysis has been carried out to study the effect of wind speed variation on DC bus voltages and mitigation of this effect on critical load. An assessment was made by changing the wind speed in the proposed methodology. Initially, wind speed is decreased from 12 to 6 m/s at a time period of one second. Then the wind speed is increased from 6 to 8 m/s at a delay time of 2 s and to 10 m/s at gap of 3 s. Finally, it is increased from 10 to 12 m/s at 4 s. Because of the variation in wind speed, the output power of the PMSG rectifier is reduced from 2,800 W to 1,450 W at the time of one second. PMSG

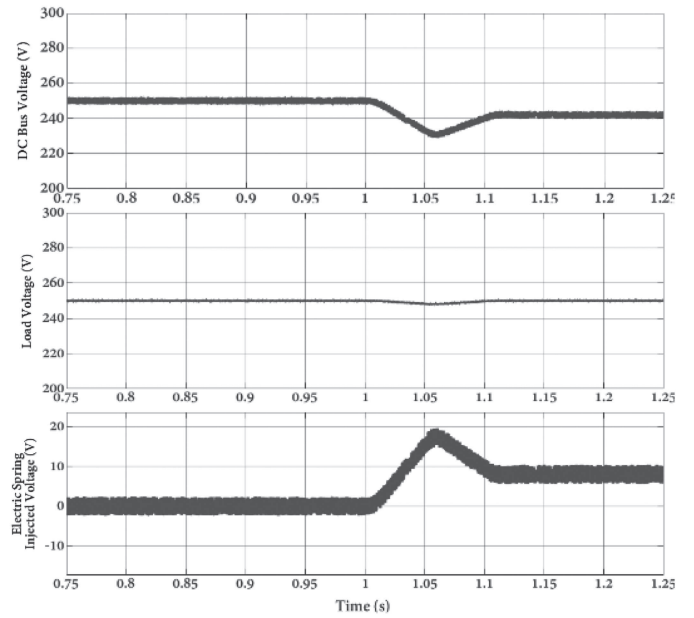

Figure 19. Transient behavior of Voltages during Irradiance decrease.

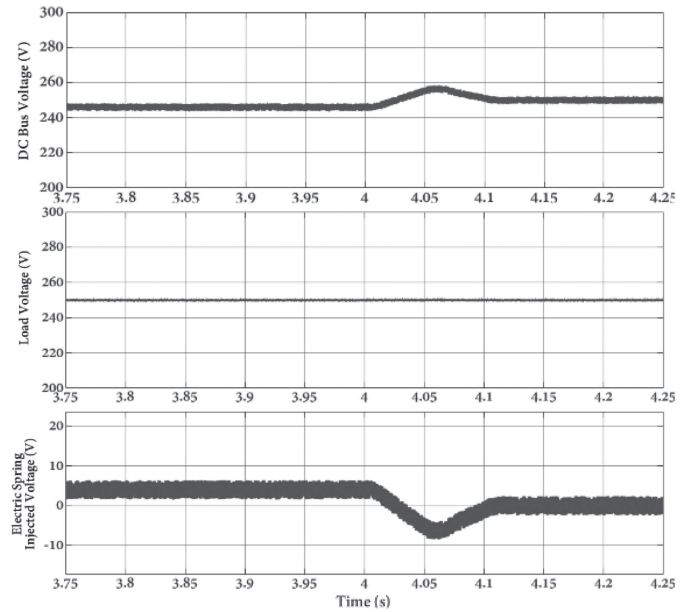

Figure 20. Transient behavior of Voltages during Irradiance increase.

rectifier delivers improved output power, when the speed of wind is increased. The characteristic curves of wind speed, PMSG rectifier output power, voltage and current are shown in Fig. 21. Similarly, the waveforms for the case of constant irradiance are presented in Fig. 22. Fuel cell output power, voltage and current for wind speed change are shown in Fig. 23. It is recorded that PMSG rectifier output voltage is subside to 73 V from 150 V, when the wind speed is varied from 12 to 6 m/s. As soon as the wind speed is increased, the rectifier output also increases and settled at 12 m/s during the time of 4 s. Because of the variation in PMSG rectifier output voltage, DC bus voltage may get affected. The reason is that the power



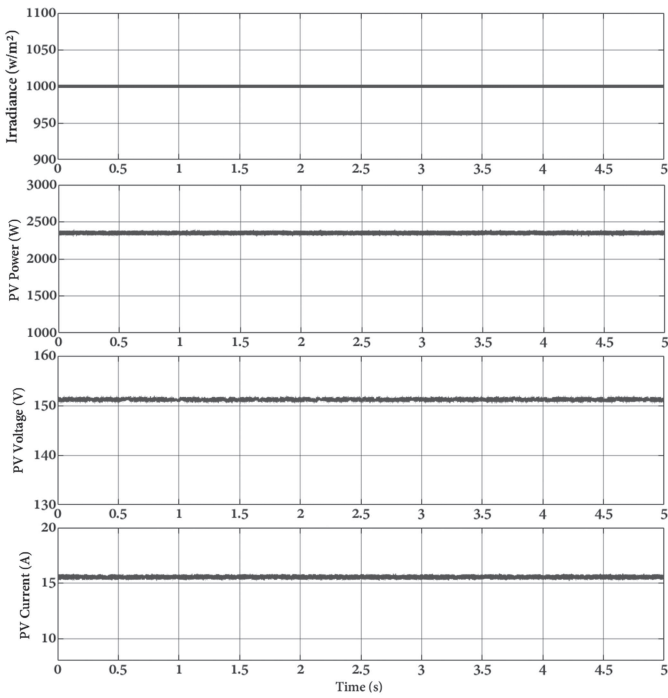

Figure 21. Irradiance, PV power, PV voltage and PV current during constant Irradiance.

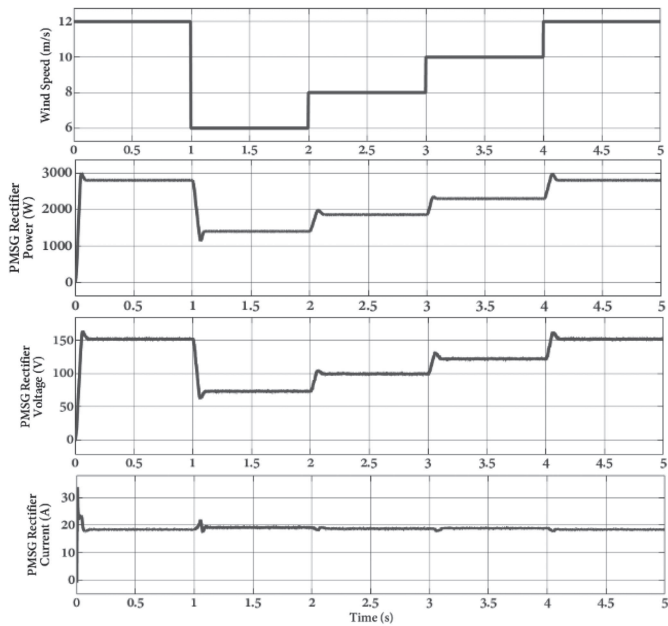

Figure 22. Wind speed, PMSG rectifier output power, voltage and current.

sharing by wind generation for a load is maximum when compared with other sources in microgrid. Then the DC bus voltage is decreased to 200 V from 250 V, when the wind speed is reduced. To maintain/ensure the voltage of the critical load to be constant, the proposed electric spring injects the required voltage support. The injected voltage from electric spring and load voltage are shown in Fig. 26. Disruption in DC bus voltages is due to the variation in wind speed. The disruption caused by variation in wind

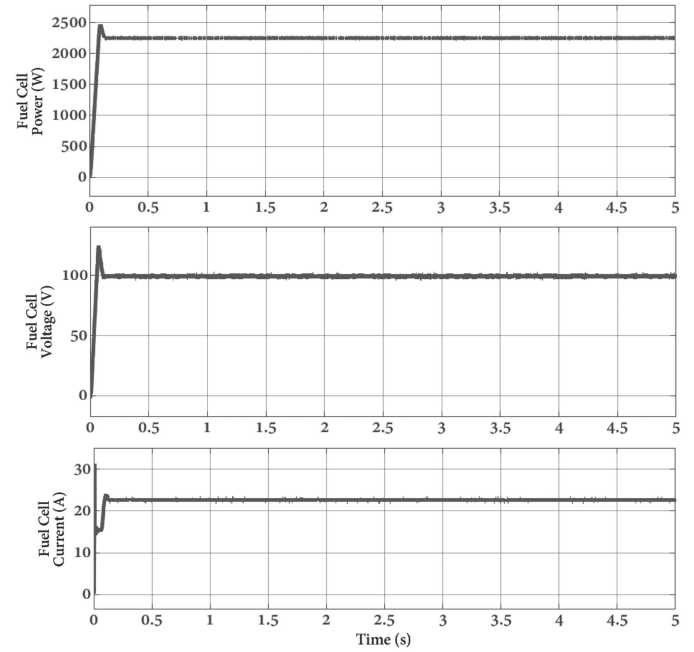

Figure 23. Fuel cell output power, voltage and current.

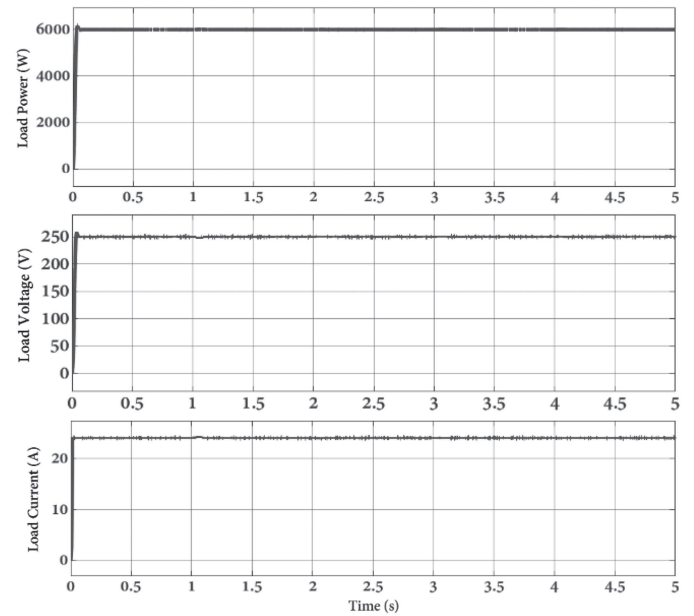

Figure 24. Load power, voltage and current for 6 KW load.

speed is in the range of 185–267 m/s, and these fluctuations are reduced and critical load voltage is maintained almost constant. DC voltage ripples are also minimized by the electric spring by the injection of voltage support.

## 7. Conclusion

This paper proposes a methodology based on electric spring with a view of stabilizing the voltages of DC bus in microgrid in the event of voltage variations due to weather changes. The main intention of the work is to protect the critical loads from the vulnerable situations. DC microgrid is designed with wind and PV as renewable energy sources,

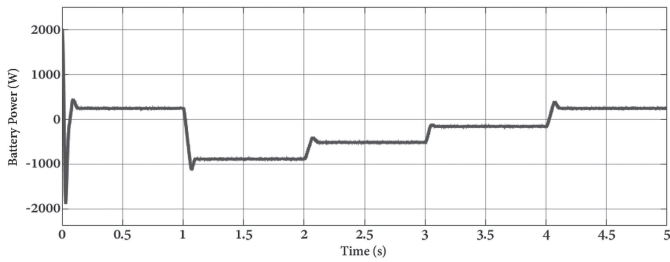

Figure 25. Battery Power.

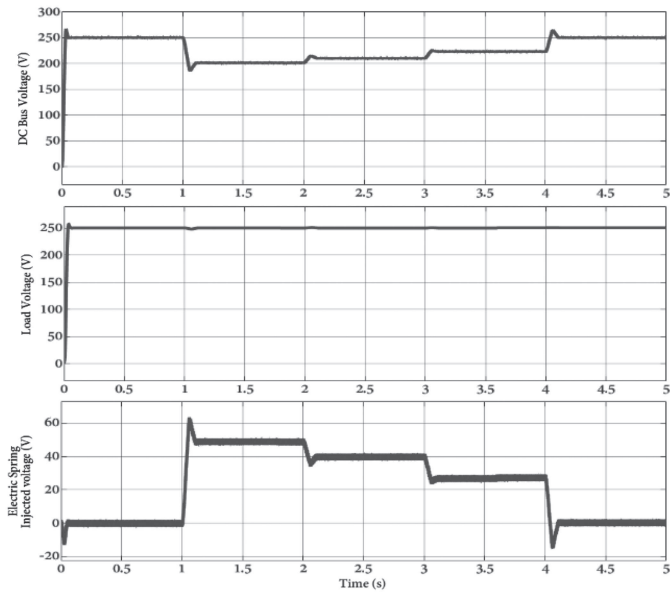

Figure 26. DC bus voltage, Load voltage and electric spring injected voltage during change in wind speed.

battery and fuel cell as storage devices and critical and non-critical loads at utility side. INC-based MPPT algorithm is implemented on solar DC-DC converter to extract maximum power from PV cell in respective atmospheric conditions. Maximum power from PMSG is extracted using DC voltage regulated MPPT algorithm. Battery as storage device is connected to DC bus through DC-DC bidirectional converter and converter output voltage is regulated using outer voltage loop and inner current loop. Critical loads are protected from the voltage fluctuations by applying the technology of electric spring which is connected directly at the load side. Electric spring is connected in series with non-critical load which acts like a smart load and thereby it minimizes the ripples and stabilizing the voltages to critical loads. The performance of the proposed method has been evaluated by means of simulation in MATLAB/SIMULINK platform. The outcomes of the simulations have been recorded and presented for validation. From the results, it is concluded that the proposed method has the ability to minimize the ripples and stabilizes the voltages of DC bus in microgrid with a view of protecting the critical loads.

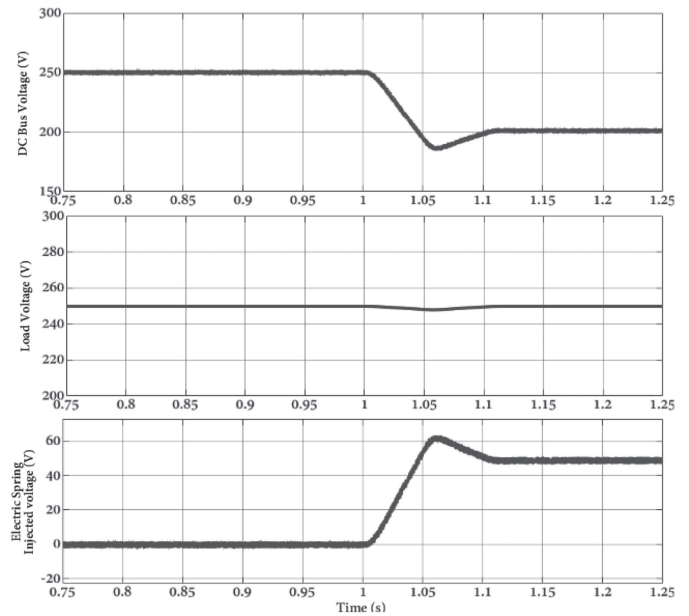

Figure 27. Transient behavior of Voltages during wind speed decrease.

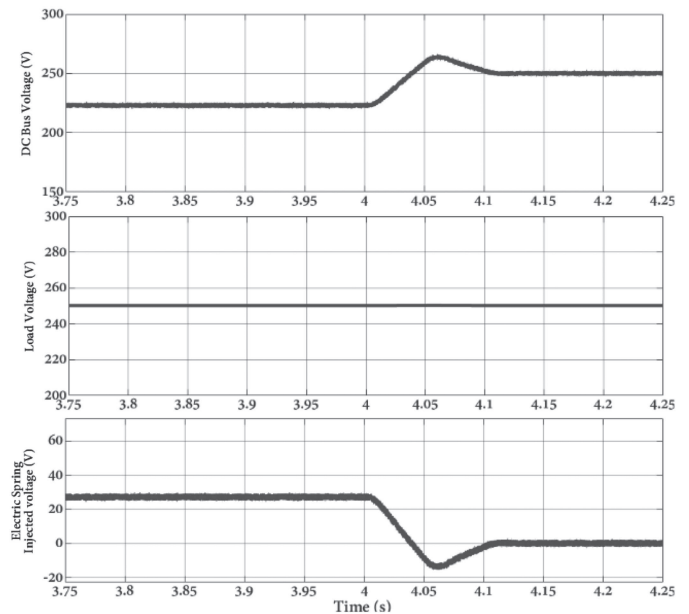

Figure 28. Transient behavior of Voltages during wind speed increase.

### Acknowledgement

The authors are gratefully acknowledge the authorities of Annamalai University for the facilities offered to carry out this research work.

### References

- [1] J. Kathiresan, S.K. Natarajan, and G. Jothimani, Energy management of distributed renewable energy sources for residential DC microgrid applications, *International Transactions on Electrical Energy Systems*, 30(3), 2020, e12258.

- [2] D. Kumar, F. Zare, and A. Ghosh, DC microgrid technology: system architectures, AC grid interfaces, grounding schemes, power quality, communication networks, applications, and standardizations aspects, *IEEE Access* 5 (2017): 12230–12256.
- [3] Shakweh, Yahya, and Eric A. Lewis. Assessment of medium voltage PWM VSI topologies for multi-megawatt variable speed drive applications, *30th Annual IEEE Power Electronics Specialists Conference. Record. (Cat. No. 99CH36321)*. Vol. 2. IEEE, 1999.
- [4] A. Iovine, *et al.*, Power management for a DC MicroGrid integrating renewables and storages, *Control Engineering Practice*, 85, 2019, 59–79.
- [5] X. Li, *et al.*, Robust and autonomous dc bus voltage control and stability analysis for a DC microgrid, *2016 IEEE 8th International Power Electronics and Motion Control Conference (IPEMC-ECCE Asia)*. IEEE, 2016.
- [6] S. Bhattacharjee and C. Nandi, Design of a voting based smart energy management system of the renewable energy based hybrid energy system for a small community, *Energy*, 214, 2021, 118977.
- [7] H. Lotfi and A. Khodaei, AC versus DC microgrid planning, *IEEE Transactions on Smart Grid*, 8(1), 2015, 296–304.
- [8] Y. Ito, Y. Zhongqing, and H. Akagi, DC microgrid based distribution power generation system, *The 4th International Power Electronics and Motion Control Conference, IPEMC 2004*. Vol. 3. IEEE, 2004.
- [9] S. Bhattacharjee, S. Chakraborty, and C. Nandi, An optimization case study of hybrid energy system in four different regions of India, *Advances in Greener Energy Technologies*. Springer, Singapore, 2020, 399–437.
- [10] A. Silani, *et al.* Output regulation for voltage control in DC networks with time-varying loads, *IEEE Control Systems Letters* 5(3), 2020, 797–802.
- [11] G.C. Kryptonidis, *et al.*, A coordinated droop control strategy for overvoltage mitigation in active distribution networks, *IEEE Transactions on Smart Grid*, 9(5), 2017, 5260–5270.
- [12] T. Morstyn, *et al.*, Unified distributed control for DC microgrid operating modes, *IEEE Transactions on Power Systems*, 31(1), 2015, 802–812.
- [13] A. Khorsandi, *et al.*, Automatic droop control for a low voltage DC microgrid, *IET Generation, Transmission and Distribution*, 10(1), 2016, 41–47.
- [14] N.L. Diaz, *et al.*, Fuzzy-logic-based gain-scheduling control for state-of-charge balance of distributed energy storage systems for DC microgrids, *2014 IEEE Applied Power Electronics Conference and Exposition-APEC 2014*. IEEE, 2014.
- [15] L. Gao, *et al.*, A DC microgrid coordinated control strategy based on integrator current-sharing, *Energies*, 10(8), 2017, 1116.
- [16] F. Zhao, *et al.*, Small-signal modeling and stability analysis of DC microgrid with multiple type of loads, *2014 International Conference on Power System Technology*. IEEE, 2014.
- [17] L. Yang, *et al.*, Second ripple current suppression by two bandpass filters and current sharing method for energy storage converters in DC microgrid, *IEEE Journal of Emerging and Selected Topics in Power Electronics*, 5(3), 2016, 1031–1044.
- [18] H. Kakigano, *et al.*, DC micro-grid for super high quality distribution—System configuration and control of distributed generations and energy storage devices, *2006 37th IEEE Power Electronics Specialists Conference*. IEEE, 2006.
- [19] S. Bhattacharjee and C. Nandi, Design of an industrial internet of things-enabled energy management system of a grid-connected solar wind hybrid system-based battery swapping charging station for electric vehicle, *Applications of Internet of Things*. Springer, Singapore, 2021. 1–14.
- [20] J. Mohammadi and F.B. Ajaei, Adaptive voltage-based load shedding scheme for the DC microgrid, *IEEE Access*, 7, 2019, 106002–106010.
- [21] T. Yang, *et al.*, Electric springs with coordinated battery management for reducing voltage and frequency fluctuations in microgrids, *IEEE Transactions on Smart Grid*, 9(3), 2016, 1943–1952.
- [22] N. Vafamand, *et al.*, Robust non-fragile fuzzy control of uncertain DC microgrids feeding constant power loads, *IEEE Transactions on Power Electronics*, 34(11), 2019, 11300–11308.
- [23] Q. Wang, M. Cheng, and Y. Jiang, Harmonics suppression for critical loads using electric springs with current-source inverters, *IEEE Journal of Emerging and Selected Topics in Power Electronics*, 4(4), 2016, 1362–1369.
- [24] Y. Chen, *et al.*, An adaptive voltage regulation control strategy of an electric spring based on output current feedback, *IEEE Transactions on Electrical and Electronic Engineering*, 14(3), 2019, 394–402.
- [25] J. Liao, *et al.*, Decoupling control for DC electric spring-based unbalanced voltage suppression in a bipolar DC distribution system, *IEEE Transactions on Industrial Electronics*, 68(4), 2020, 3239–3250.
- [26] A.G. Anu, R. Hari Kumar, and S. Ushakumari, Power quality enhancement of DC micro-grid using DC electric spring, *Advances in Smart Grid Technology*. Springer, Singapore, 2020, 137–148.
- [27] C.K. Lee, S.C. Tan, F.F. Wu, S.Y.R. Hui and B. Chaudhuri, Use of Hooke’s law for stabilizing future smart grid – The electric spring concept, *2013 IEEE Energy Conversion Congress and Exposition*, 2013, 5253–5257, doi: 10.1109/ECCE.2013.6647412.
- [28] S.Y. Hui, C.K. Lee, and F.F. Wu, Electric springs—a new smart grid technology, *IEEE Transactions on Smart Grid*, 3(3), 2012, 1552–1561, doi: 10.1109/TSG.2012.2200701.
- [29] M. Yin, *et al.*, Modeling of the wind turbine with a permanent magnet synchronous generator for integration, *2007 IEEE Power Engineering Society General Meeting*. IEEE, 2007.
- [30] Z. Jin, *et al.*, Admittance-type RC-mode droop control to introduce virtual inertia in DC microgrids, *2017 IEEE Energy Conversion Congress and Exposition (ECCE)*. IEEE, 2017.
- [31] S. Moon, S. Jou, and K. Lee, State-space average modeling of bidirectional DC-DC converter for battery charger using LCLC filter, *2014 International Power Electronics Conference (IPEC-Hiroshima 2014 – ECCE ASIA)*, 2014, 224–229, doi: 10.1109/IPEC.2014.6869584.

## Biographies



Mrs. P. NagaLakshmi received her B.Tech degree in Electrical and Electronics Engineering from Jawaharlal Nehru Technological University, Kakinada, India in 2005 and M.Tech with Power Electronics and Drives from Vignan’s University, Guntur, India in 2011. She is having 12 years of teaching experience. She is currently working as Assistant Professor in the Department of Electrical and Electronics Engineering, Bapatla Women’s Engineering College, Bapatla, India. She is pursuing Ph.D in the Department of Electrical Engineering under Annamalai University, Tamil Nadu and her research interests are in the area of Application of Power Electronics to Power systems.



*Dr. R. Ashok Kumar* is presently the Professor of Electrical Engineering, Annamalai University, India. His research interest includes Power system Operation and Control, Design Analysis of Electrical Machines, Radial Distributed System and Deregulated Power System Studies. He has published many reports and journal articles in the research area. He received M.E degree (Power

System Engineering) in 1999 and Ph.D degree in 2009 both from Annamalai University. In 1994, he joined Annamalai University as a Lecturer and then elevated to the level of Professor. He is a member of ISTE and other technical bodies.



*Dr. K. Hari Krishna* received his B.Tech degree in Electrical and Electronics Engineering from Jawaharlal Nehru Technological University, Kakinada, India in 2003 and M.Tech with Power Systems from Acharya Nagarjuna University, Guntur, India in 2006. He received Ph.D degree from the Acharya Nagarjuna University, Guntur, India in 2017. He is having 16 years of teaching and

research experience. He is currently Professor in the Department of Electrical and Electronics Engineering, Kallam Haranadhareddy Institute of Technology, Guntur, India. His research interests are in the area of Power System Operation and Stability.